



Mobilität im Alter Bewegungs- und Begegnungsorte

Jenny Leuba, Projektleiterin, Fussverkehr Schweiz
Älter werden im Sensebezirk - Tafers 20. September 2018



Was muss man im Alltag können?

- 🚶 Autonomie: die ersten 300m sind wesentlich
- 🚶 Alternative zum eigenen Fahrzeug





Wieso Bewegung fördern?

- 🚶 Gesundheit: Bewegung 20 Min./Tag 2.5 Std./Woche
- 🚶 Alltagsmobilität hat mehr Potenzial als Sport

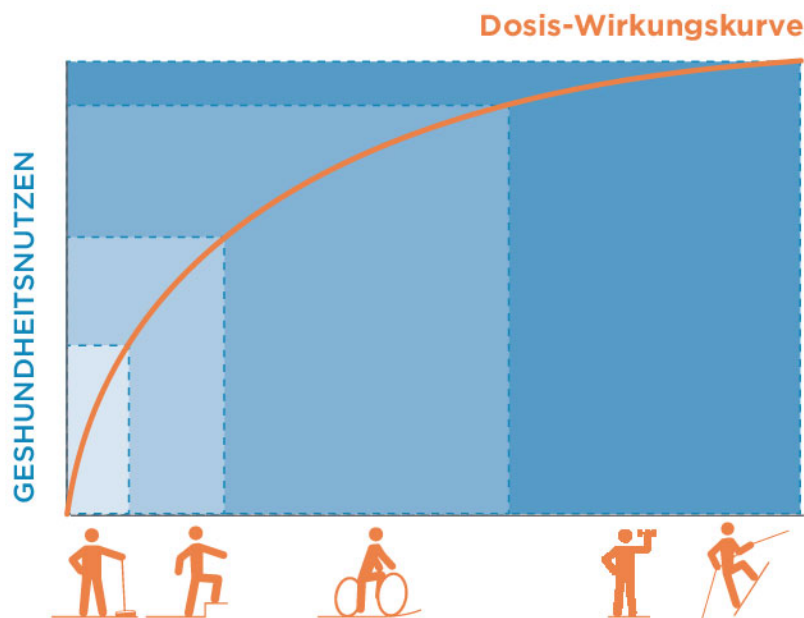

AUSMASS DES BEWEGUNGSVERHALTENS GEMÄSS
DER PYRAMIDE S. 26

Legende



Leichte
Alltagsaktivitäten



2½ Stunden pro Woche
leicht «ins Schnuufe» kommen,
zum Beispiel 5 Mal ½ Stunde
pro Tag; auch möglich durch
«ins Schwitzen» kommen



Training von Ausdauer, Kraft
und Beweglichkeit (für ältere
Personen auch Gleichgewicht),
mehrmals pro Woche



Zusätzliche
Sportaktivitäten



Wo bewegen?





Aufgabe der Gemeinde: Alltagsmobilität gewährleisten





Sitzbank: Netzgedanke

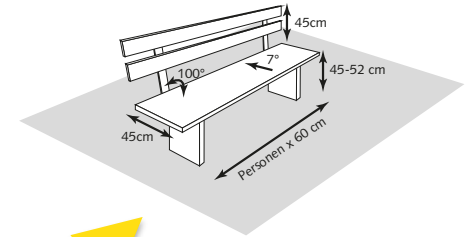

300m – 100m

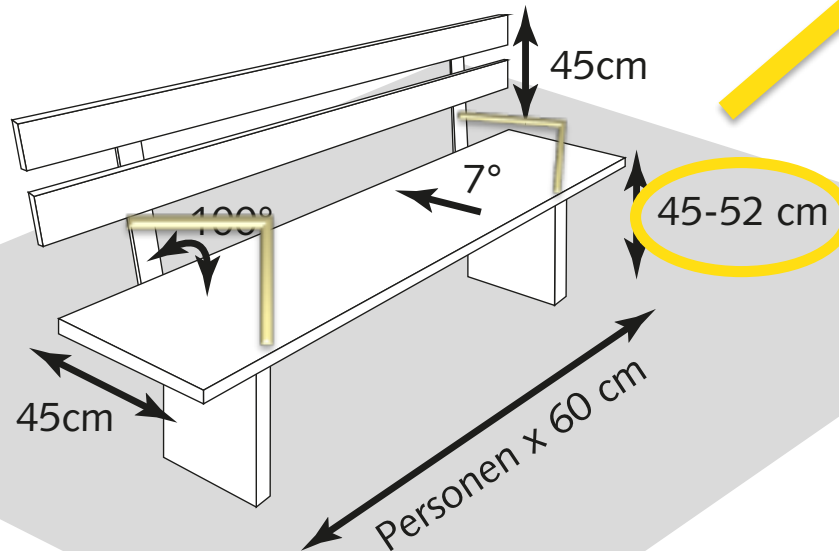



Funktion: Begegnungs- und Genussbank









Funktion: Ruhebank





Senior-Check: zu Fuss in Neuchâtel

Sitzbank, Handlauf, Trottoirabsenkung, Wartezeit an der Ampel,
steile Strecken, Sicherheitsgefühl





Bank vs. Stuhl





Informelle Sitzgelegenheiten ...



... laden zum Sitzen ein



Unerwartetes: Sicherheitsprobleme





Details ...





Referenzen

- 🚶 Qualität von öffentlichen Räumen, Methoden zur Beurteilung der Aufenthaltsqualität, Fussverkehr Schweiz 2015
- 🚶 Sitzen im öffentlichen Raum, Fussverkehr Schweiz, 2015
- 🚶 VSS Norm SN 641 075 Hindernisfreier Verkehrsraum
- 🚶 Mobilité et territoires de vie des aînés, Fondation Leenards, 2016
- 🚶 Praxis Beispiel «Analyse der Fussgängerfreundlichkeit und der Sitzgelegenheiten für ältere Menschen» Plattform MobilService 2017

Wir sitzen alle auf der selben Bank!

HOLDING
GRAZ
LINIEN



fb.com/mobilite.pietonne/



[@fussverkehr](https://twitter.com/fussverkehr)



[@fussverkehr](https://www.instagram.com/fussverkehr)



linkedin.com/company/fussverkehr

Jenny Leuba - Fussverkehr Schweiz
Klosbachstrasse 48, 8032 Zürich
fussverkehr.ch/alter
jenny.leuba@fussverkehr.ch